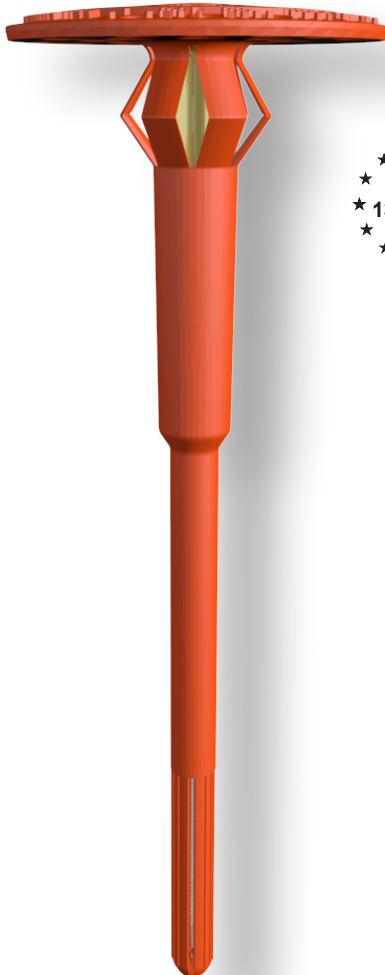

**BRAVOLL® PTH-EX****Picture****Description**

Steel nail hammer-in anchor for fixing expanded polystyrene (EPS) and mineral wool insulation boards in external wall systems (ETICS).

**Technical data**

European Technical Approval:	ETA 13/0951
Technical guidelines:	ETAG 014
Use categories acc.to ETAG 014:	A - B - C - D
Washer diameter $d_p$ :	60 mm
Drilling diameter $d_o$ :	8 mm
Minimum embedment depth $h_{nom}$ :	25 mm
Minimum drilling depth $h_f$ :	$h_{nom} + 10 - 15$ mm
Minimum insulation thickness $h_d$ :	80 mm
Point thermal transmission $\chi$ :	0.001 W/K
Anchor plate load resistance:	1.4 kN
Anchor plate stiffness:	0.6 kN/mm
Anchor body material:	shock-resistant polypropylene
Expansion pin material:	Galvanized steel and polyamide

**Features**

- One-piece expansion pin for easy setting
- Special deformation area for a perfect finish
- Low thermal conductivity
- Low embedment depth - quick drilling
- High pull-out values - lower quantity of anchors per m<sup>2</sup>
- Special plate surface for optimum render adhesion
- Suitable for high thickness insulation boards
- Premounted anchor
- Can be used in connection with **BRAVOLL® IT PTH** washers

Anchor type BRAVOLL®	Code	Total length $L_a$ (mm)	max. insulation thickness $h_d$ (mm)	max. insulation thickness $h_d$ (mm)	Quantity per carton (pcs)
			new <sup>1)</sup>	renovation <sup>2)</sup>	
Material categories:			A - B - C - D		
PTH-EX 135	12011	135	100	80	200
PTH-EX 155	12012	155	120	100	100
PTH-EX 175	12013	175	140	120	100
PTH-EX 195	12014	195	160	140	100
PTH-EX 215	12015	215	180	160	100
PTH-EX 235	12016	235	200	180	100
PTH-EX 255	12017	255	220	200	100
PTH-EX 275	12018	275	240	220	100
PTH-EX 295	12019	295	260	240	100
PTH-EX 315	12020	315	280	260	100

<sup>1)</sup> For a 25 mm embedment and 10 mm of glue ( $a_2$ )

<sup>2)</sup> For a 25 mm embedment, 20 mm of old render ( $a_1$ ) and 10 mm of glue ( $a_2$ )

## Technical data

Anchor type BRAVOLL®	PTH-EX
Base material	characteristic resistance $N_{RK}$ (kN)
Concrete C 12/15 acc. to EN 206-1	0.9
Concrete C 16/20 - C 50/60 acc. to EN 206-1	1.2
Solid bricks acc. to EN 771-1	0.9
Sand-lime solid bricks acc. to EN 771-2	0.9
Hollow blocks from aerated concrete acc. to EN 771-3	0.75
Lightweight aggregate concrete acc. to EN 1520 (LAC)	0.6
Hollow bricks acc. to EN 771-1	0.6
Vertically perforated clay bricks acc. to ÖNORM B 6124	0.75
Minimum edge distance $c_{min}$ (mm)	100
Minimum spacing $s_{min}$ (mm)	100
Minimum thickness of member $h$ (mm)	100

## Drawing

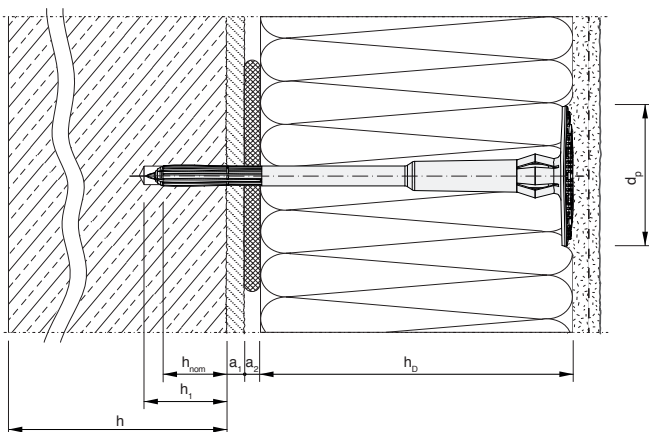

## Anchor length calculation

$$L_a \geq h_D + h_{nom} + \max a_1 + \max a_2$$

- $d_p$  - washer diameter
- $L_a$  - anchor length
- $h_D$  - insulation material thickness
- $h_{nom}$  - minimum embedment
- $h_{ef}$  - effective embedment depth
- $h_1$  - minimum drilling depth
- $h$  - base material thickness
- $a_1$  - render thickness
- $a_2$  - gluing mortar thickness + facade surface flatness tolerance

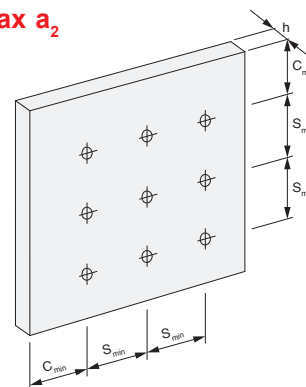

## Installation

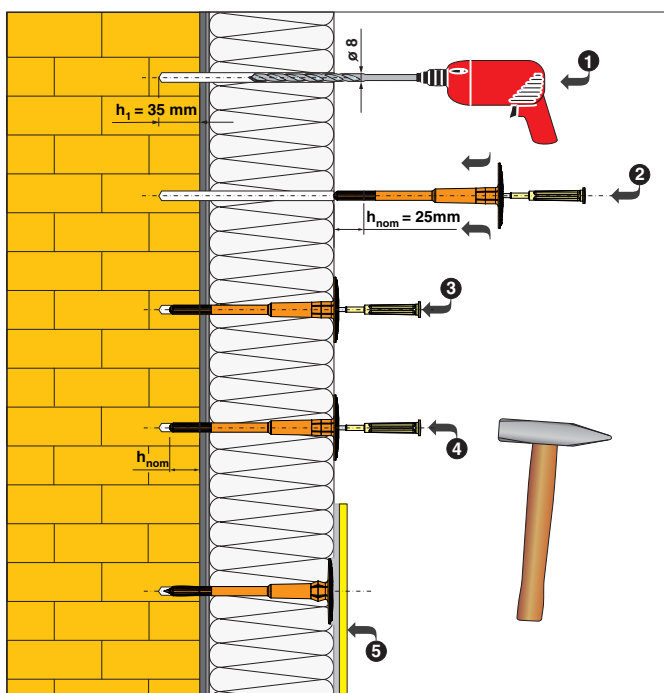

- Drill a hole through the insulation board to the right diameter. Hollow bricks should be drilled without hammering (ideally with a specially designed drill bit).
- Insert the anchor into the hole with the anchor plate flush in contact with the insulation material. Slightly hammer the anchor plate in order to push it between 0 and 2 mm under the insulation material surface.
- If the anchor is difficult to set, it probably means that the used drill bit is worn (the drilled diameter is too small or the dust remains inside the hole). It is then necessary to use a new drill bit or better clean the hole.
- Hammer the head of the pin until it becomes flush with the anchor plate.
- A 800g hammer is recommended to perform an optimal installation.
- Within 6 weeks the anchors should be covered by the other ETICS components (for UV protection).
- When levelling surface make sure to respect the minimum embedment depth.
- Installation must be done at a temperature  $> 0^\circ\text{C}$ .